

REVISIONS		
No./Date	Description	By

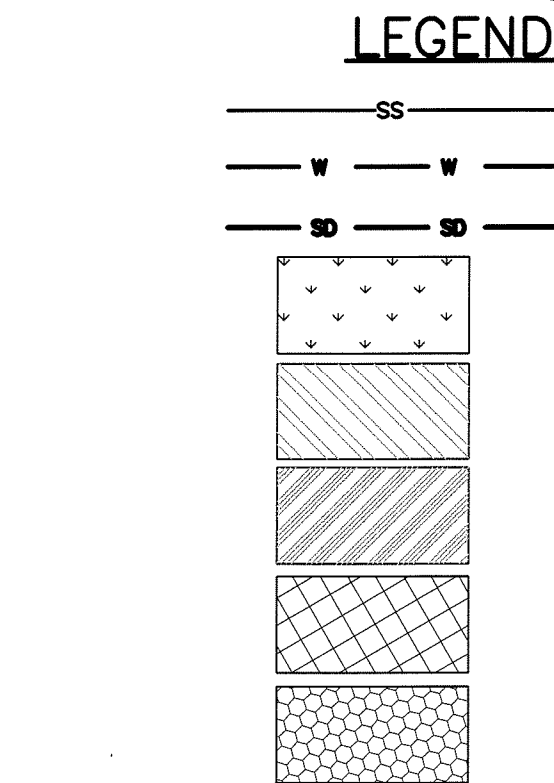

- NOTES:
- TOPOGRAPHY AND TREE SURVEY COMPLETED BY GARY W. KEYES LAND SURVEYING P.C.
 - STREET LIGHTS TO BE INSTALLED.
 - ROADS ARE PUBLIC AND SHALL BE DESIGNED PER NCDOT STANDARDS.
 - ALL IMPERVIOUS AREAS ARE TO DRAIN TO THE ENGINEERED STORM DRAINAGE SYSTEM.
 - 10' NON-MUNICIPAL EASEMENT ALONG ALL STREET FRONTAGE.
 - THE HOA WILL BE RESPONSIBLE FOR THE SIDEWALK MAINTENANCE, STORM WATER FACILITIES AND RECREATION AREA.
 - ALL LOTS SHALL BE GRADED TO THE STREET OR DRAINAGE SWALE OR YARD INLETS.
 - SUITABLE MATERIAL SHALL BE USED ON ANY LOTS THAT ARE REQUIRED TO BE FILLED.
 - 'NO PARKING ON STREET ANYTIME' SIGNAGE SHALL BE PROVIDED.
 - PROJECT NOT LOCATED WITHIN 100-YR FLOOD ZONE PER FIRM MAP NUMBER 3720316900 DATED APRIL 3, 2006.
 - NO PARKING, OBSTRUCTIONS, OR GATES WILL BE ALLOWED WITHIN THE PUBLIC RIGHTS-OF-WAY.
 - PARKING TO BE LOCATED WITHIN PRIVATE DRIVEWAYS.

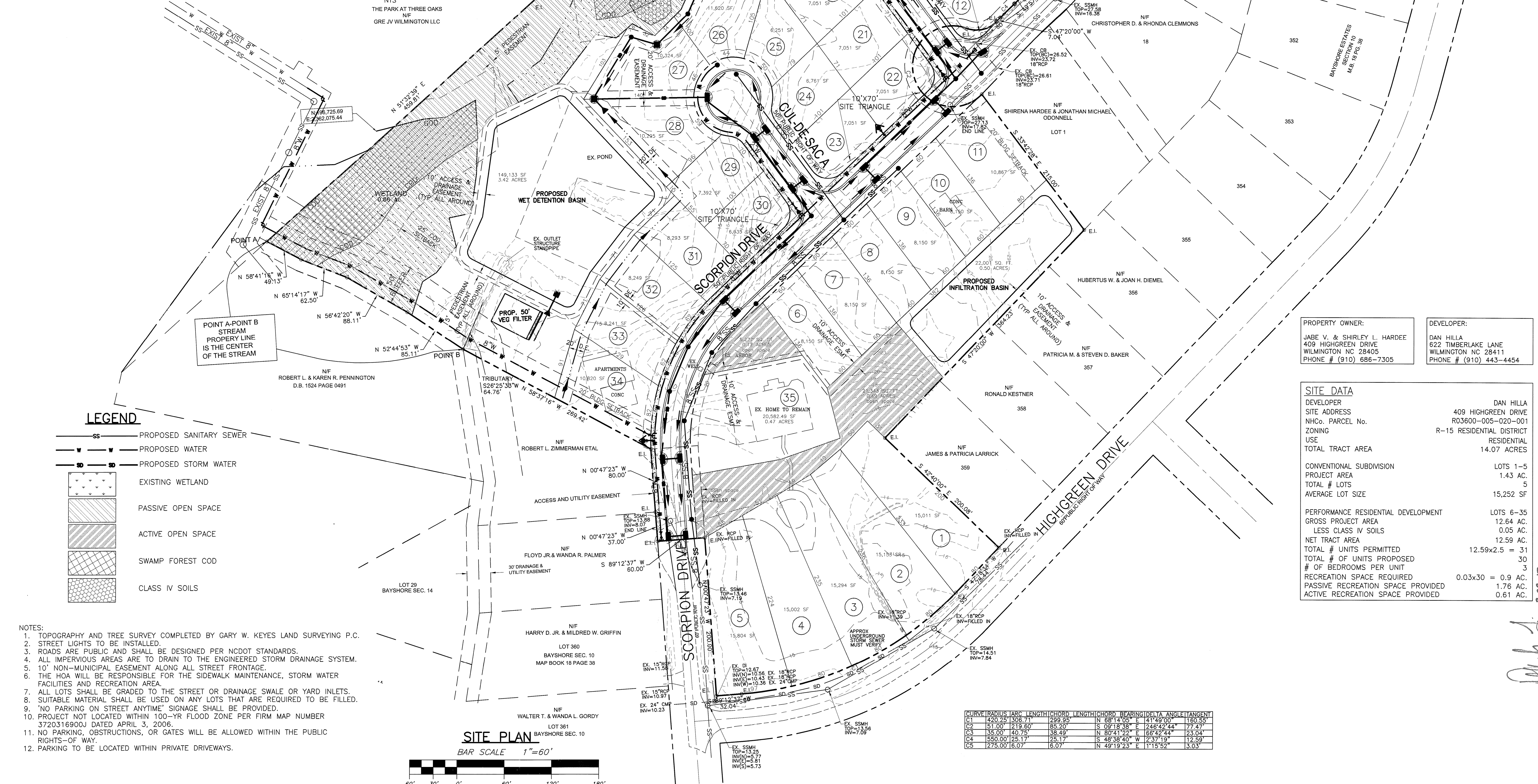
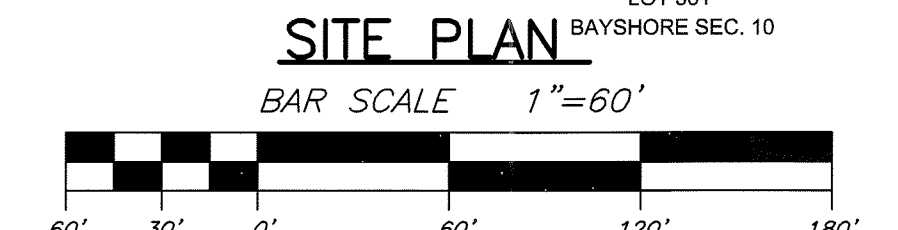

CURVE	RADIUS	ARC LENGTH	CHORD LENGTH	CHORD BEARING	DELTA ANGLE	TANGENT
C1	420.25	306.71	299.95	N 88°14'05" E	41°49'00"	180.55
C2	51.00	219.60	85.20	S 09°18'38" E	246°42'44"	77.47
C3	35.00	40.75	38.49	N 80°41'22" E	65°42'44"	23.04
C4	550.00	125.17	25.17	S 49°38'40" W	23°37'19"	12.59
C5	275.00	6.07	6.07	N 49°19'23" E	1°15'52"	3.03

PROPERTY OWNER:
JABE V. & SHIRLEY L. HARDEE
409 HIGHGREEN DRIVE
WILMINGTON NC 28405
PHONE # (910) 686-7305

DEVELOPER:
DAN HILLA
622 TIMBERLAKE LANE
WILMINGTON NC 28411
PHONE # (910) 443-4454

SITE DATA

DEVELOPER	DAN HILLA
SITE ADDRESS	409 HIGHGREEN DRIVE
NHCo. PARCEL No.	R03600-005-020-001
ZONING	R-15 RESIDENTIAL DISTRICT
USE	RESIDENTIAL
TOTAL TRACT AREA	14.07 ACRES

CONVENTIONAL SUBDIVISION	LOTS 1-5
PROJECT AREA	1.43 AC
TOTAL # LOTS	5
AVERAGE LOT SIZE	15,252 SF

PERFORMANCE RESIDENTIAL DEVELOPMENT	LOTS 6-35
GROSS PROJECT AREA	12.64 AC.
LESS CLASS IV SOILS	0.05 AC.
NET TRACT AREA	12.59 AC.
TOTAL # UNITS PERMITTED	12.59x2.5 = 31
TOTAL # OF UNITS PROPOSED	30
# OF BEDROOMS PER UNIT	3
RECREATION SPACE REQUIRED	0.03x30 = 0.9 AC.
PASSIVE RECREATION SPACE PROVIDED	1.76 AC.
ACTIVE RECREATION SPACE PROVIDED	0.61 AC.

TRC PLAN
CONVENTIONAL AND PERFORMANCE RESIDENTIAL
CATHERINE'S COVE
WILMINGTON, NORTH CAROLINA

TRIPP ENGINEERING, P.C.
419 Chestnut Street
Wilmington, North Carolina 28401
Phone 910-763-5100
Fax 910-763-5631
© 2006 TRIPP ENGINEERING, P.C.

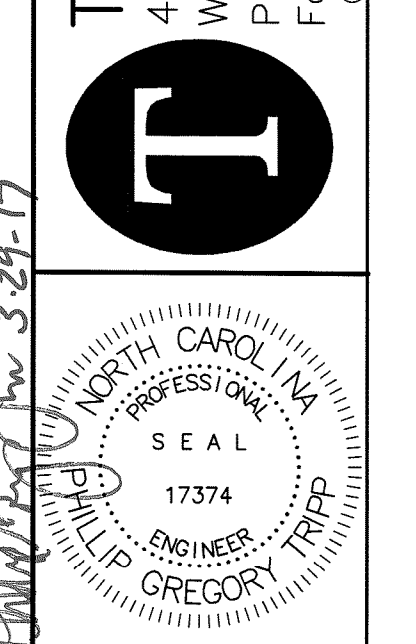

DATE 03-29-17
DESIGN PGT
DRAWN MLV

C1
SHEET 1 OF 1
17020