

- GENERAL NOTES:**
1. NEW HANOVER COUNTY PARCEL NOS.:  
PIN# 314809.06.7069.000  
PID R04900-001-014-000
  2. TOTAL AREA: 3.62 AC.± ~ 157,713 SF
  3. EXISTING ZONING: R-5, CONDITIONAL MODERATE-HIGH DENSITY
  4. BUILDING USE: RESIDENTIAL

**Development Data:**  
 Total Tract Area - 3.62 ac.  
 minus Class IV Soils - 0-  
 (not applicable)  
 minus Natural water features - 0-  
 (not applicable)  
 Total Development Area - 3.62 ac.

- Site Inventory Notes:**
1. Soils Type: Be (Baymeade fine sand)
  2. This property is not impacted by any AEC.
  3. There are no Conservation Overlay boundaries affecting this property.
  4. This site is not impacted by any recognized historic or archeological significance.
  5. No cemeteries were evidenced on the site.
  6. Existing vegetation will be located during detailed design & permitting.
  7. There is no evidence of jurisdictional wetlands on the site.
  8. There is no evidence of endangered species or habitat issues on the site.
  9. A small portion of this property is within a special flood hazard area as evidenced on FIRM Panel 3720314800J / AE 14.2.
  10. The site drainage flows into the Smith Creek drainage basin.

**Performance Residential Density -**  
 3.60 ac. @ 8.0 units/ac. (R-5 Density) =  
 Total Units Permitted - 29  
 \*\* 22 Units Proposed \*\*  
 (Density = 6 units per acre)

**Surface Coverage:**

|                    |                      |
|--------------------|----------------------|
| Buildings -        | 22,020 s.f.±         |
| Roadway -          | 26,455 s.f.±         |
| Sidewalk -         | 5,185 s.f.±          |
| Concrete Walkway - | 900 s.f.±            |
| House Patios -     | 2,640 s.f.±          |
| Driveways -        | 9,051 s.f.±          |
| Total -            | 64,251 s.f.± (40.9%) |

**Recreation Space -**  
 22 x 0.03 ac./unit = 28,750 s.f. required  
 \*\* Total Rec Area Prov'd. - 28,897+ s.f. \*\*  
 (Note: There are no wetlands or specific impediments to the recreation areas being active or passive in their use.)

- Development Notes:**
1. All development shall be in accordance with the New Hanover County Zoning Ordinance.
  2. Project shall comply with all Federal, State & New Hanover County regulations.

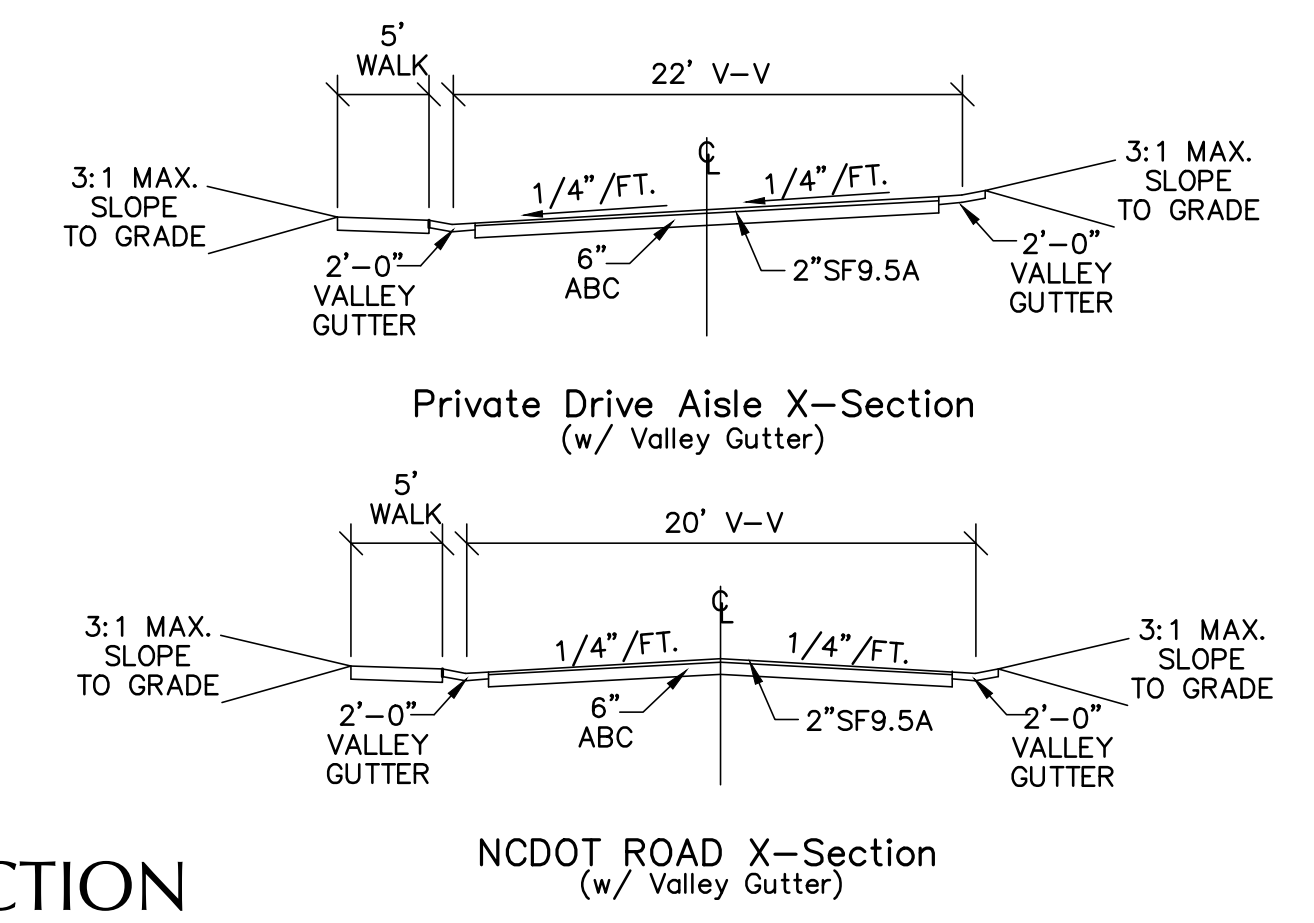

- Utility Notes:**
1. Existing water and sanitary sewer services are currently available to the site from Cape Fear Public Utility Authority public mains.
  2. All utility services, such as electric power, CATV, gas & telephone shall be installed underground.
  3. All water & sewer utilities to be installed per CFPWA Technical Specifications & Standards. Call 343-3910 for information.
  4. Project shall comply with CFPWA Cross Connection Control requirements. Water meter(s) cannot be released until all requirements are met and N.C.D.E.N.R. has issued their "Final Approval."
  5. Any backflow prevention devices required by the CFPWA will need to be on the list of approved devices by USCFCCHHR or ASSE.
  6. The contractor is responsible for the location and protection or existing utilities during construction. Call U-LOCO at 1-800-632-4949. Contractor is responsible for the repair and replacement of any utilities, curb & gutter, pavement, etc. that may be damaged during construction. Damaged items shall be repaired to at least the quality or workmanship found in the original item.
  7. Solid waste disposal will be by individual residence cart pickup by a private contractor / hauler.
  8. Street lights will be provided.

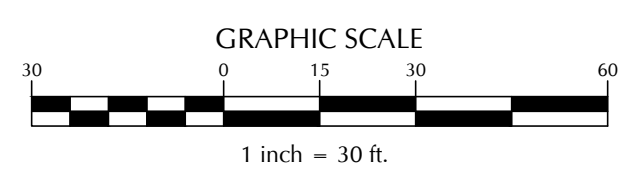

PRELIMINARY DESIGN - NOT RELEASED FOR CONSTRUCTION

| No. | Revision | Date | By |
|-----|----------|------|----|
|     |          |      |    |
|     |          |      |    |
|     |          |      |    |

|            |     |         |               |
|------------|-----|---------|---------------|
| Designer   | MNH | Scale   | AS SHOWN      |
| Drawn By   | MNH | Date    | JANUARY, 2021 |
| Checked By | MNH | Job No. |               |

**SPRING RIDGE**

NEW HANOVER COUNTY NORTH CAROLINA

DMRW1, LLC  
 P.O. BOX 35798  
 WILMINGTON, NC 28406

PORT CITY CONSULTING  
 ENGINEERS, PLLC  
 6216 STONEBRIDGE ROAD  
 WILMINGTON, NC 28409  
 910-599-1744 LICENSE No. P-1032

**TRC PLAN**

Sheet No.  
**C-TRC**